

< SMI Meeting >

**Current Activities of
ISO/TC 227 *Springs***

September 26th, 2009 Las Vegas, U.S.A.

Shigeo Aiba

**Secretary of ISO/TC 227 – Springs
Japan Spring Manufacturers Association
(JSMA)**

Contents

1. ISO/TC 227 : The current organization
2. ISO/TC 227 : Meetings
3. ISO/TC 227 : Scope and Business Plan
4. International Standards for springs
 - Publication status —
 - Developmental status —
5. The next ISO/TC 227 Meeting

1. ISO/TC 227 : The current organization

- Establishment : November 2004
- Chairman: Mr. Horst D. Dannert (Germany)
- Secretary: Mr. Shigeo Aiba (Japan)
- P-members: start with 7 nations → **12 nations**
China, France, Germany, Italy, Japan, South Korea,
U.K.,
Philippines ('05/11~), **Malaysia** ('06/11~), **Thailand** (O→P '07/2~),
India ('07/3~), **Austria** ('07/10~)

→ **6 nations**
- O-members: start with 7 nations (Canada), (Spain), (Switzerland), (Thailand),
Brazil, Poland, Slovakia,
Viet Nam ('06/7~), **Finland** ('07/8~), **Hong Kong China** ('08/6~)

Canada('08/5), Spain('08/5), Switzerland('07/12)

Withdrawal from O- :

P-member: Participating member, O-member: Observation member

2. ISO/TC 227: Meetings



2. ISO/TC 227 : Meetings

Participants (P-members)

1st meeting: Tokyo, Japan; Aug. 2005

5 nations: Japan, China, France, Germany, S.Korea

2nd meeting: Achern, Germany; Oct. 2006

5 nations : Germany, France, Japan, S.Korea, U.K.

3rd meeting: Beijing, China; Oct. 2007

9 nations : China, France, Germany, Japan,
Malaysia, Philippines, S.Korea, Thailand, U.K.

4th meeting: Bangkok, Thailand; Nov. 2008

11 nations : Austria, China, France, Germany, Italy,
Japan, Malaysia, Philippines, S.Korea, Thailand, U.K.

3. ISO/TC 227 : Scope & Business Plan

Scope

Standardization in the field of metal springs covering exclusively product tolerances, terms and test methods and process technology for springs. (heat treatments, surface treatment, shot peening, etc.)

Excluded: Product specifications solely intended to cover each application, since some of them are currently in the scope of existing TC.

3. ISO/TC 227 : Scope & Business Plan

Business Plan

Cat-egory	Technical domain	Titles of ISO standards
I	Terminology / Classification (infrastructure building) →	<ul style="list-style-type: none">• Vocabulary ('06 -'09)• Symbols ('09 -)
II	Tolerance →	<ul style="list-style-type: none">• Hot formed helical compression springs ('08 -)
III	Inspection/ Test method	
IV	Processing →	<ul style="list-style-type: none">• Shot peening ('06 -'09)

4. International Standards for springs

— Publication status —

- **ISO 26910-1: Springs – Shot peening: Part 1: General Procedures**

Publication date: **June 15, 2009** (development period: 3 years)

Project team members: 9 P-members

Japan (leader), China, France, Germany, Malaysia,
Philippines, South Korea, Thailand, U.K.

- **ISO 26909: Springs – Vocabulary**

Publication date: **July 1, 2009** (development period: 5 years)

Project team members: 9 P-members

Japan (leader), China, France, Germany, Malaysia,
Philippines, South Korea, Thailand, U.K.

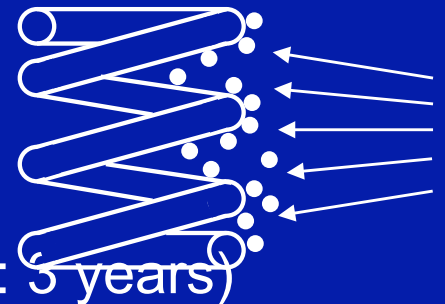

4. International Standards for springs

— Publication status —

- ISO 26910-1:
Springs – Shot peening:
Part 1: General Procedures
(English version, French version)

Including;
Terms and definitions,
Strategies for conducting the shot
peening,
Peening media,
Almen strip,
Method of measurements,
Shot peening machine,
Control of shot peening, etc.

7 Method of measurement

7.1 Measurement of Almen arc height

Almen arc height, h , shall be measured, on the unpeened surface of an Almen strip, as the height of the midpoint e from a reference plane defined by the points a , b , c and d , as shown in Figure 3. Almen arc height shall be determined to a resolution of 0,01 mm by appropriate means. Annex C supplies information about a commonly used device, known as the Almen gauge.

Almen arc height, h , shall be expressed with the class of test strip in parentheses, as in the following examples.

EXAMPLE 1 0,35 mm (A): Almen arc height of 0,35 mm by Almen strip A.

EXAMPLE 2 0,20 mm (C): Almen arc height of 0,20 mm by Almen strip C.

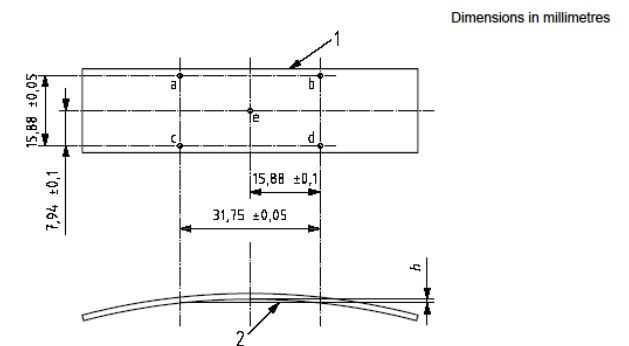

Figure 3 — Definition of Almen arc height

7.2 Evaluation of coverage

Coverage shall be evaluated either on a spring surface or a suitable reference surface as agreed upon by the purchaser and supplier. The numerical value shall be rounded to the nearest of 5 % step in accordance with ISO 31-0.

Coverage may be determined by comparing the magnified photographs of peened surface with the standard photographs given in Annex A.

A supplemental strip or coupon may be used to evaluate the coverage by agreement between the purchaser and supplier. It should have an equivalent hardness to the spring to treat and be fixed on a solid holder similar to the test strip holder. Its surface is preferably polished with a buff for easy observation.

4. International Standards for springs

— Publication status —

- ISO 26909: Springs–Vocabulary (English, French together)

Including 253 terms, definitions, classification chart, figures

(The existing ISO 2162-3:1993 (TC 10/SC 6), which had 33 spring terms only, was replaced to ISO 26909 and then abolished.)

1.2

compression spring

spring (1.1) that offers resistance to a compressive force applied axially

See Figure A.1.

NOTE In the narrow sense, a compression spring indicates a helical compression spring.

1.3

extension spring

spring (1.1) that offers resistance to an axial force tending to extend its length, with or without initial tension

1.2

ressort de compression

ressort (1.1) qui s'oppose à une force de compression axiale

Voir Figure A.1.

NOTE Au sens étroit, un ressort de compression indique un ressort de compression hélicoïdal.

1.3

ressort de traction

ressort (1.1) qui s'oppose à une force axiale tendant à allonger la longueur du ressort, avec ou sans tension initiale

4. International Standards for springs

— Publication status —

Other IS standards relating to springs

- ISO 2162-1:1993 Technical product documentation—Springs—
Part 1: Simplified representation (TC 10/SC 6)
- ISO 2162-2:1993 Technical product documentation—Springs—
Part 2: Presentation of data for cylindrical helical compression springs
(TC 227 transferred from TC 10/SC 6)
- ISO 8748:2007 Straight-type spring pins—Coiled, heavy duty
(TC 2/SC 10 same as below)
- ISO 8749:1986 Pins and grooved pins—Shear test
- ISO 8750:2007 Straight-type spring pins—Coiled, standard duty
- ISO 8751:2007 Straight-type spring pins—Coiled, light duty
- ISO 8752:1997 Straight-type spring pins—Slotted, heavy duty
- ISO 13337:1997 Straight-type spring pins—Slotted, light duty

4. International Standards for springs

— Developmental status —

- ISO/CD 11891: Springs – Hot formed helical compression springs – Technical specifications (Finish in 2011)

Project team members: 8 P-members

China (leader), France, Germany, Japan, Malaysia, South Korea, Thailand, U.K.

- ISO/WD nnnnn: Springs – Symbols (Finish in 2013)

Project team members: 11 P-members

Japan (leader), Austria, China, France, Germany, Italy, Malaysia, Philippines, South Korea, Thailand, U.K.

4. International Standards for springs

— Developmental status —

Development schedule (★ --- Registration, 😊 --- finish)

	2007	2008	2009	2010	2011	2012	2013
Hot comp. springs	NP → ★ WD		CD	DIS	FDIS 😊		
Symbols		NP, WD	★ CD	DIS	FDIS 😊		

NP: New Work Item Proposal, WD: Working Draft, CD: Committee Draft,
DIS: Draft International Standard, FDIS: Final Draft International Standard

5. The next ISO/TC 227 Meeting



Shrigley Hall Hotel

- The 5th meeting in Manchester, U.K.
- Date: November 12th to 13th, 2009
- Host: BSI
(British Standard/British Standards Institute)
- Participants expected: 12 P-members
Austria, China, France, Germany, India, Italy, Japan
Malaysia, Philippines, South Korea, Thailand, U.K.
- Discussion drafts:
 1. Hot formed helical compression springs – Technical specifications
CD deliberation → make the revision of CD
 2. Symbols
NP, WD approval → to be proceeded to a CD stage

Thank you for your attention

JSMA (Japan Springs Manufacturers Association)
<http://www.spring.or.jp/english/english.html>